



# QUARTERLY

## Ala Moana Honolulu, Hawaii

A Mainland "Mainstay" Has Joined the Islands

Now there is no longer a need to forego a visit to the city of Honolulu, because Nordstrom has a new full-line store opening soon at Ala Moana Shopping Center. The 210,000 square foot store, located at 1519 Kapiolani Boulevard, provides all of the amenities Nordstrom clients have come to enjoy here on the mainland: Nordstrom-quality service and Nordstrom-quality products but presented in a Pacific environment.

Relative to environments the HVAC systems for this outstanding facility have been designed to maintain the same high standards expected of mainland stores while being a good neighbor environmentally. One of the challenges of this application was to provide a high-comfort mechanical system, minimize utility system infrastructure needs and simultaneously create a small environmental footprint. Daytime power costs on the islands are quite high, set to encourage off-hour consumption. To minimize the consumption of daytime electricity, a full thermal ice storage system was employed. The system uses off-peak power to cool a storage medium; in this case, ice. Off-peak power is provided at a significant reduction in cost to the consumer and helps the utility balance off-peak and on-peak power requirements, avoiding increased infrastructure costs. The ice inventory is built using low-temperature chillers circulating a brine solution through water-filled tanks. Each tank is rated at approximately 186 ton-hours of capacity. A total of 48 tanks were used, providing 8,967 ton-hours of capacity. The reference to "full-storage" (as opposed to "partial-storage") refers to the system's ability to create and store enough ice to satisfy a full day's cooling needs without energizing mechanical refrigeration systems.



**Nordstrom - Ala Moana rooftop tank farm and air handlers**

In a typical thermal ice storage system, the thermal storage tanks would be located in a below-grade or basement area. At Nordstrom Ala Moana Center, the thermal storage tanks are located in a "tank-farm" on the roof of the building. This was necessary because of the high water table at the site. Although not typical design practice (because of the structural impact), one advantage of the Ala Moana layout is the close proximity of the thermal ice storage tanks, air handlers and mechanical room equipment, keeping piping costs to a minimum.

Six central chilled-water air handlers were used to serve the majority of the store. The air handlers are Variable Air Volume, providing superior zone comfort control. There are small, dedicated, self-contained units serving other areas.

Several energy-conserving design features were integrated into the mechanical systems. These included the use of decoupled variable speed pumping, optimized chilled and condenser water temperature controls, the use of series fan-powered terminal VAV boxes at all perimeter zones, critical zone reset strategy and the use of variable speed drives for all variable flow fans.

PSF is very proud to have been a team member on this unique and exciting project.

### UPCOMING PROJECTS

#### Nordstrom Projects

- Keystone Fashion Mall  
Indianapolis, IN
- Cherry Hill  
Cherry Hill, NJ
- Kenwood  
Cincinnati, OH
- Short Hills Remodel  
Short Hills, NJ
- The Oaks  
Thousand Oaks, CA

#### Local Projects

- Redmond Software Bldg 92
- Redmond Software Lab 87
- NW Hospital CT Scan
- 1124 Columbia Street "C" Level AFYA
- Cellnetix
- Swedish Hospital OPA

### INSIDE THIS ISSUE

Completed Projects.....	2
Tech Talk .....	3
PSF Employee Spotlight.....	3
PSF People .....	4

## May we introduce you to the Technology of Turbocor?

Ask us about a compressor technology so advanced it's creating a revolution! Save 50% on energy costs!

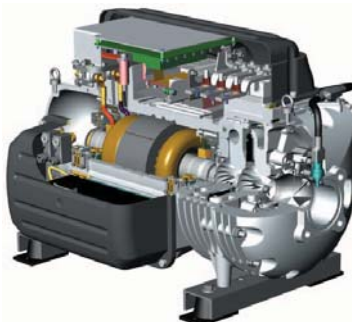

### A refrigeration compressor that ...

- Contains no bearings
- Has its own brain
- Never needs oil
- Stays quiet
- Has no locked rotor amp rating
- Is environmentally friendly



### Nordstrom Rack Southcenter Square

- 34,788 ft<sup>2</sup> Single-level Retail Space (26,946 ft<sup>2</sup> retail, w/7,842 ft<sup>2</sup> office/stock room)
- Tailor/Alteration Shop
- Loss Prevention Monitoring Room
- Tukwila, WA

#### Team Members:

- GC - Newland Construction
- Architect - Callison Architects, Inc.
- HVAC - PSF Mechanical, Inc.

#### HVAC Systems:

- (6) Trane rooftop AC units, 125 tons of cooling
- (5) Fan induction terminals for back offices and dressing rooms
- Trane Summit EMCS DDC
- Sales floor controlled by constant volume AC control



### Trubion Pharmaceuticals, Inc.

- 35,352 ft<sup>2</sup> Lab/Office Tenant Improvement
- Seattle, WA

#### Team Members:

- GC - BNBuilders
- Architect - Stock & Associates
- HVAC - PSF Mechanical, Inc.

#### HVAC Systems:

- Office areas served by house hydronic heat pumps
- Labs served by (2) 50 Ton 100% OSA gas-fired Dx cooling units
- The server room is served by a 3-ton mini-split

#### Energy-Saving Strategies:

- Employed DDC controls as extension of existing system
- Heat reclaim in cold weather and free pre-cooling in hot weather
- Use of SCR controllers on electric zone heating coils



### Redmond Software Company

- 18,766 ft<sup>2</sup> Office Space
- 2-Story Tenant Improvement
- Redmond, WA

#### Team Members:

- GC - Skanska, USA
- Architect - KDW Architects & Engineers
- HVAC - PSF Mechanical, Inc.

#### HVAC Systems:

- Critical rooms served by dedicated split system units with redundant service from building VAV System
- (2) outdoor rooftop units to alternate operations 24/7/365
- (2) 100% redundant dry coolers and pumps with glycol circulating loop

#### Energy-Saving Strategies:

- ECM motors for fan terminal units
- VFD's for all rooftop air-handling units

## Thermal Ice Storage Honolulu, Hawaii

Recently we had the opportunity to design and build an Ice Thermal Storage Plant for Nordstrom at the Ala Moana Shopping center in Honolulu (see separate article this newsletter).

Thermal Ice storage is one of a number of cold thermal storage solutions which also includes chilled water and eutectic salts. Ice was chosen at Ala Moana for a number of reasons: ice storage systems provide the highest density; the melting point of eutectic salts is too high to provide chilled water temperatures that will provide good dehumidification; the ice storage was available in modular units that could be easily shipped to Hawaii and craned to the roof.

A typical thermal ice storage system consists of air- or water-cooled ice-making chillers, pumps and ice storage tanks. During off-peak hours, the ice-making chillers are run freezing the water in the tanks by circulating 15 to 26 °F glycol solution through heat exchange coils in the storage tanks. During day-time hours the glycol solution is circulated through the tanks while the chillers are off. The melting ice cools the glycol solution to serve the day-time cooling load without operating the chillers.

Two situations where it could be beneficial to use thermal storage are: (1) where the electric utility offers a favorable off-peak rate; (2) where adding thermal storage capacity in lieu of adding chillers is more cost-effective and/or running chillers at night improves chiller plant efficiency because of lower night-time temperatures.

Thermal energy storage systems are financially attractive if incentive rates are given by the utility companies, as at Ala Moana. These rates are used when the utilities need to shift load to off-peak hours because of a shortage of generating capacity, or the desire to avoid activating back-up generating equipment which is often more costly to run. There are currently no off-peak rates in Washington State. The focus for thermal storage in Washington is on reducing load.

Thermal energy storage systems provide the means of shifting full or partial HVAC electrical load from peak day-time use to off-peak hours. The choice of which strategy to use depends on the utility rate structure. At Ala Moana, for instance, the chillers, cooling tower and condenser water pumps are on a separate off-peak rate structure that makes it favorable to use storage system shifting.



Ice Storage Tank Farm



Circulating Pump at Ala Moana



Chillers at Ala Moana

### PSF EMPLOYEE SPOTLIGHT

#### Craig Randall, Senior Project Engineer

Craig's greatest passion is boat racing, specifically "circle racing inboard flat-bottom runabouts", and he's been at it for more than twenty years. His interest was piqued by a neighbor with a boat shop on his property where Craig—a teenager at the time—was eventually invited to work.

This type of boat racing offers three different engine-sized classes. Craig has four engines and his favorite is his methanol-fueled, super-charged, 526 c.i. Big Block Chevrolet

with 1900 horsepower. His average course speed is about 100 mph with top speeds of 140 mph. As you might guess, this is a risky hobby. Like most of the fellow racers in his community, Craig retro-fitted his boat with a safety capsule (enclosed cockpit) which requires a full-time air supply system (see photo).

Craig is a member of the Seattle Drag & Ski Boat Association who hosts races on area lakes April through October. There are national



Craig's boat on Lake Tapps



Craig Randall

races hosted by the American Power Boat Association throughout the United States all year long and Craig competes in several of them.

Craig is well-known on the boat-racing scene; he has chaired many races and

managed festivals, been a course official in many more including Seattle's Seafair, and his teams have set five world speed records. We always breathe a sigh of relief when Craig shows up to work on Mondays in one piece!

## Meet the People That Make Things Happen



**Dan Cushman returns to PSF Mechanical as a Senior Project Engineer.** He has over 16 years of experience in the industry and holds a Bachelor's degree in Mechanical Engineering from Seattle University. In his free time he enjoys skiing, traveling, motorcycling and fishing.



**Meghan Sarmiento, Production Operations Administrative Assistant,** brings 7 years of experience as an Administrative Assistant from both for-profit and non-profit organizations. In her free time she enjoys hiking in the great outdoors of the Pacific Northwest.



**Mark Kaminsky returns to PSF Mechanical as a Senior Project Engineer.** He has over 17 years of experience in the industry and holds a Bachelor's degree in Industrial Engineering from the University of Tennessee. Mark enjoys snow and water skiing as well as beach volleyball in his spare time.



**Wayne Lawson, Piping Superintendent,** has over 25 years of experience in the industry. He oversees PSF's new Plumbing and Piping Division making PSF a full service Mechanical Contractor. In his spare time he enjoys sporting clays.



**Kevin McLean, Senior Project Manager,** has over 26 years of industry experience and holds a Bachelor's degree in Construction Management from Oregon State University. In his spare time he enjoys spending time with his kids, golfing and fishing.



**Dana Hannan, Project Manager,** has joined PSF's SPTI group, bringing over 25 years of experience in the plumbing, piping and HVAC industry. When Dana's not working you're likely to find him on local waterways enjoying his boat and a line in the water at his favorite fishing hole.

### MAILBAG

#### Like to get on our mailing list?

Send your name and address or email address to:

[sales@psfmech.com](mailto:sales@psfmech.com)

Or, simply write to:

**PSF Mechanical, Inc.**  
9322 14th Avenue South  
Seattle, WA 98108

For more information or key contacts list, visit our web site at:

[www.psfmechanical.com](http://www.psfmechanical.com)



**PSF Mechanical, Inc.**

*"Trusted to be the Better Choice"*

9322 14th Avenue South  
Seattle, WA 98108-5102